

Owner's Manual

Model Numbers:

DF3215
DF3215NH

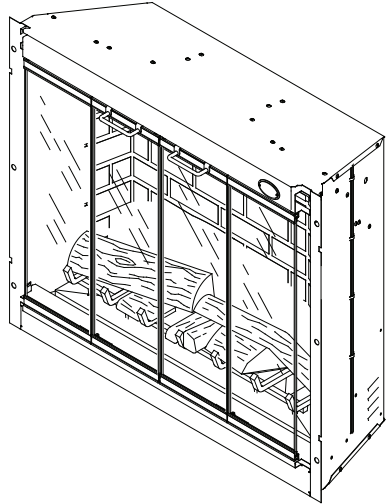

Serial Number _____

Model Number _____

Part Number _____

Quality checked by:

Valued Customer,

Thank you and congratulations for purchasing a Dimplex electric fireplace. Over the years, valuable memories will occur around the warmth and comfort of your hearth. Thank you for allowing our product to be the backdrop for those special moments.

QUICK REFERENCE GUIDE

1. Before using the fireplace verify:
 - Are the circuit breakers for the unit on?
 - Are the light bulbs loose? (to check, follow the instructions for replacing the light bulbs under the maintenance section of this manual)
2. The heater may emit a slight, harmless odor when first used. This odor is a normal condition caused by the initial heating of internal heater parts.
3. The information regarding the model of your unit can be found on the rating plate located inside the unit. See Page 6 for an illustration on how to locate the rating plate.
4. If you have any questions or concerns regarding the operation of your fireplace, contact Dimplex customer service at 1-888-DIMPLEX (1-888-346-7539) before returning the product to the point of purchase.

CONTENTS

Important Instructions	PAGE 4
Model and Serial Number Information. . .	PAGE 6
Site Selection and Preparation	PAGE 7
Fireplace Installation	PAGE 7
Operation.	PAGE 10
Maintenance	PAGE 16
Warranty	PAGE 20

IMPORTANT INSTRUCTIONS

Retain This User's Guide For Future Reference

When using electrical appliances, basic precautions should always be followed to reduce the risk of fire, electric shock, and injury to persons, including the following:

1. Read all instructions before using the electric fireplace.
2. The heater is hot when in use. To avoid burns, do not let bare skin touch hot surfaces. The trim around the heater outlet becomes hot during heater operation. Keep combustible materials, such as furniture, pillows, bedding, papers, clothes, and curtains at least 3 feet (0.9 m) from the front of the unit (**not applicable on DF3215NH model fireplaces**).
3. Extreme caution is necessary when any heater is used by or near children or invalids and whenever the unit is left operating and unattended (**not applicable on DF3215NH model fireplaces**).
4. Always unplug the electric fireplace when not in use.
5. Do not operate any unit with a damaged cord or plug, or if the heater has malfunctioned, or if the electric fireplace has been dropped or damaged in any manner. Return heater to authorized service facility for examination, electrical or mechanical adjustment, or repair.
6. Do not use outdoors.
7. The electric fireplace is not intended for use in bathrooms, laundry areas and similar indoor locations. Never locate heater where it may fall into a bathtub or other water container.
8. Do not run the cord under carpeting. Do not cover cord with throw rugs, runners, or the like. Arrange cord away from traffic area and where it will not be tripped over.
9. To disconnect the unit, turn the controls off, then remove the plug from the outlet.
10. Do not insert or allow foreign objects to enter any ventilation or exhaust opening as this may cause an electric shock or fire, or damage to the heater.
11. To prevent a possible fire, do not block air intake or exhaust in any manner. Do not use on soft surfaces, like a bed, where openings may become blocked (**not applicable on DF3215NH model fireplaces**).
12. All electrical heaters have hot and arcing or sparking parts inside. Do not use in areas where gasoline, paint, or flammable liquids are used or stored or where the unit will be exposed to flammable vapors (**not applicable on DF3215NH model fireplaces**).
13. Do not modify the electric fireplace. Use it only as described in this

manual. Any other use not recommended by the manufacturer may cause fire, electric shock or injury to persons.

14. Avoid the use of an extension cord. Extension cords may overheat and cause a risk of fire. If you must use an extension cord, the cord must be No. 14 AWG minimum size and rated no less than 1875 Watts.
15. Do not burn wood or other materials in the electric fireplace.
16. Do not strike the fireplace glass.
17. Always use a certified electrician should new circuits or outlets be required.
18. Always use properly grounded, fused and polarized outlets.
19. Disconnect all power supply before performing any cleaning, maintenance or relocation of the unit.
20. When transporting or storing the unit and cord, keep in a dry place, free from excessive vibration and store so as to avoid damage.



CAUTION
RISK OF ELECTRIC SHOCK
DO NOT OPEN
NO USER-SERVICEABLE PARTS INSIDE



SAVE THESE INSTRUCTIONS

! NOTE: Procedures and techniques that are considered important enough to emphasize.

⚠ CAUTION: Procedures and techniques which, if not carefully followed, will result in damage to the equipment.

⚡ WARNING: Procedures and techniques which, if not carefully followed, will expose the user to the risk of fire, serious injury, illness or death.

! NOTE: This equipment has been tested and found to comply with the limits for Class B digital device, pursuant to part 15 of the FCC Rules. These limits are designed to provide reasonable protection against harmful interference in a residential installation. This equipment generates, uses and can radiate radio frequency energy and, if not installed and used in accordance with the instructions, may cause harmful interference to radio or television reception, which can be determined by turning the equipment off and on, the user is encouraged to try to correct the interference by one or more of the following measures:

- Reorient or relocate the receiving antenna.
- Increase the separation between the equipment and the receiver.
- Connect the equipment into an outlet on a circuit different from that to

which the receiver is connected.

- Consult the dealer or an experienced radio/TV technician for help.

Operation is subject to the following two conditions: (1) this device may not cause interference and; (2) this device must accept any interference, including interference that may cause undesired operation of the device.

Model And Serial Number Information

If you have any questions about our products please have the product model and serial numbers available upon calling Dimplex customer service. To locate the model and serial number see below (Figure 1). Record the Part Number, Model Number and Serial Number on the front cover of this manual for future reference.

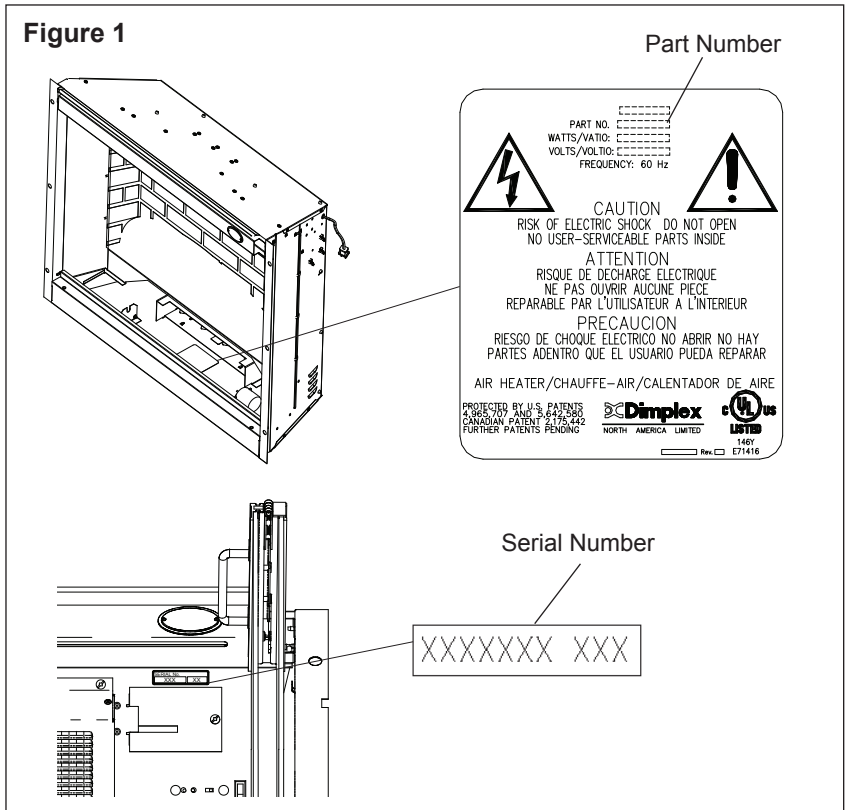

! NOTE: A 15 Amp, 120 Volt circuit is required. A dedicated circuit is preferred but not essential in all cases. A dedicated circuit will be required if, after installation, the circuit breaker trips or fuse blows on a regular basis when the heater is operating. Additional appliances on the same circuit may exceed the current rating of the circuit breaker.

⚠ WARNING: Ensure the power cord is not installed so that it is pinched or against a sharp edge and ensure that the power cord is stored or secured to avoid tripping or snagging to reduce the risk of fire, electric shock or injury to persons.

Construction and electrical outlet wiring must comply with local building codes and other applicable regulations to reduce the risk of fire, electric shock and injury to persons. Do not attempt to wire your own new outlets or circuits. To reduce the risk of fire, electric shock or injury to persons, always use a licensed electrician.

Site Selection And Preparation

This section provides instructions for selecting a location and preparing the site to install the fireplace into your Dimplex mantel surround.

1. Select a suitable location that is not susceptible to moisture and is away from drapes, furniture and high traffic.
2. For ease of electrical hook up you may wish to locate the fireplace near an existing outlet (refer to NOTE 1).
3. Store the fireplace in a safe dry and dust free location.

! NOTE: The dimensions of the fireplace are 36 ½ inches (927 mm) wide X 31 ¾ inches (806 mm) high X 13 inches (330 mm) deep. The viewing area is 32 inches (813 mm) wide and 28 ¼ (715 mm) high. The fireplace does not require any additional venting.

Fireplace Installation

1. Install the Bi-fold doors to the fireplace.

! IMPORTANT: Bi-fold doors **MUST** be installed to the firebox prior to installing firebox to mantel.

Bi-fold Door Installation (Figure 2)

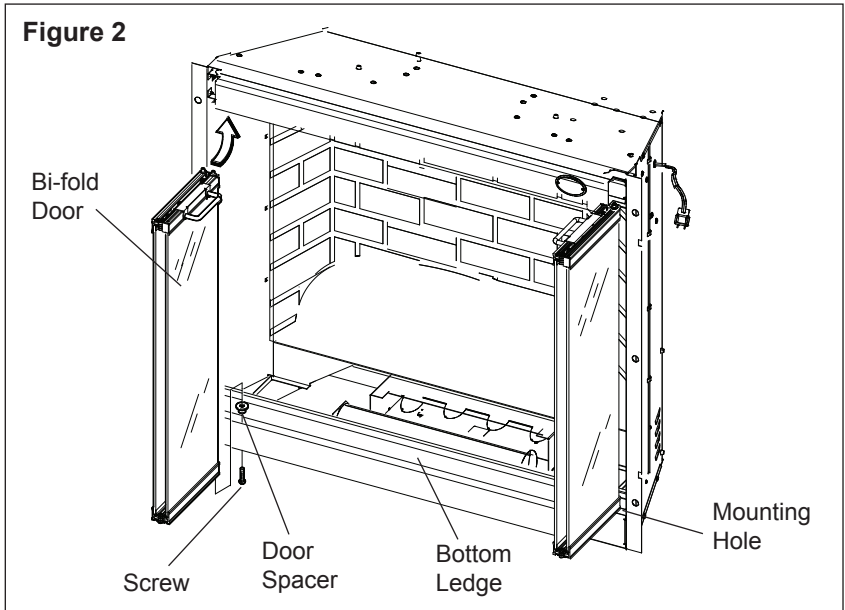

- i. Remove the Bi-fold doors from packaging.
 - ii. Remove the Philips head screw and the door spacer from the bottom edge of the Bi-fold door opposite of the door handle.
 - iii. Insert the door spacer into the bottom panel ledge mounting hole.
 - iv. Insert the top edge of the Bi-fold door into the top door track on the fireplace.
 - v. Secure the Bi-fold door to unit with supplied screw using a short handled screwdriver.
- ! NOTE:** If short handled screwdriver is not available tilt the unit back.
- vi. Repeat steps 2-5 for the other side.
2. Install the fireplace assembly into the mantel (refer to Dimplex mantel assembly instructions).

! IMPORTANT: If not using a Dimplex mantel, the fireplace must be installed in an enclosure with the following **MINIMUM** internal/opening dimensions: 32 inches (813 mm) wide x 31 $\frac{3}{4}$ inches (806 mm) high x 13 $\frac{1}{2}$ inches (343 mm) deep; and in such a way that the plug and outlet can be accessed (Figure 3).

Figure 3

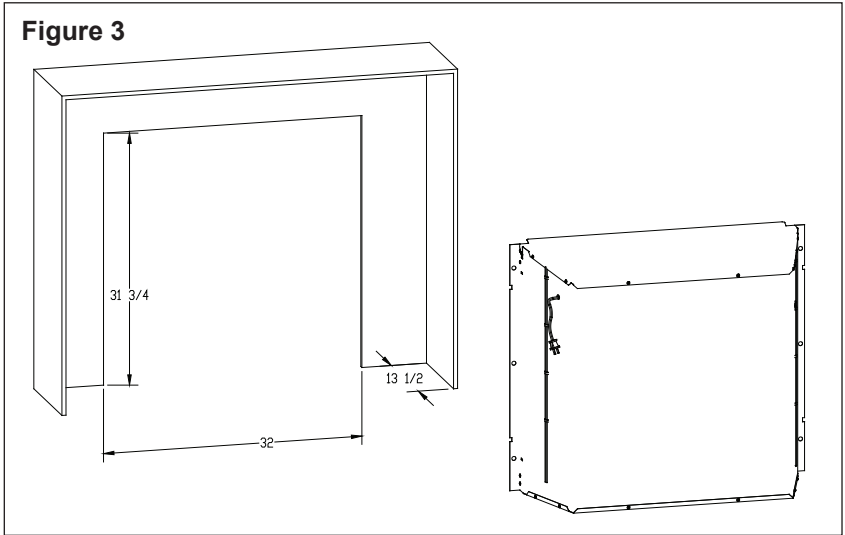

3. Removable mounting hardware must be used when installing this unit into a new wall application, this unit must be able to be removed from the opening to access the plug and outlet as well as for servicing purposes. A custom trim may be used, permitting easy and non-destructive removal.
4. Plug the unit into a 15 Amp/120 Volt outlet. If the cord does not reach, you may use an extension cord rated for a minimum of 1875 Watts.

⚠ WARNING: Ensure the power cord is not installed so that it is pinched or against a sharp edge. Also ensure the power cord is stored or secured to avoid tripping or snagging to reduce the risk of fire, electric shock or injury to persons.

Operation

Electric Fireplace Manual Control

The manual controls for the fireplace are located in the upper right hand corner (Figure 4).

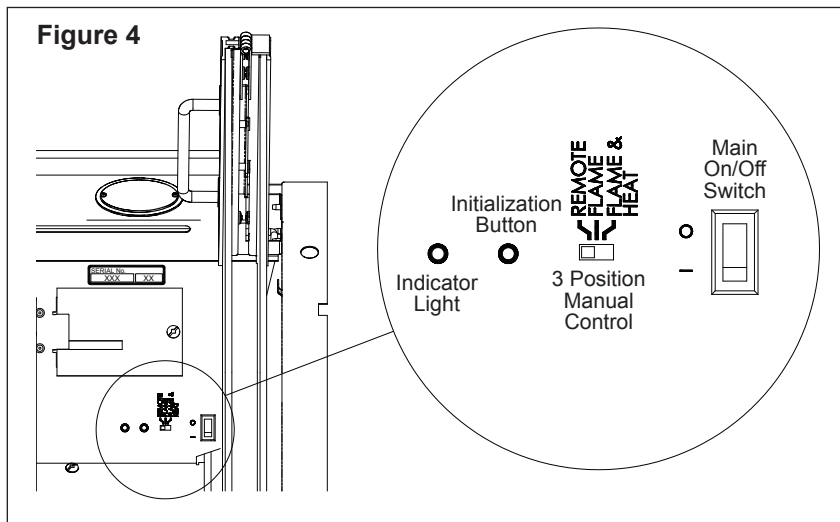

Main On/Off Switch

Supplies power to the 3 Position Manual Control Switch.

3 Position Manual Control Switch

Remote (left position): The unit is operated with the remote control.

Flame (center position): The flame effect is turned on.

Flame & Heat (right position)*: The flame effect and heater are turned on simultaneously. When the manual control is in the **Flame & Heat** position the heater does not run on the remote operated thermostat. When the heater is on the red indicator light is activated on the firebox and the fan and heater are running on low.

! NOTE: When the manual control switch is in the **Flame** and **Flame & Heat** positions, the fireplace unit will not operate with the remote control.

* Flame only function of DF3215NH

Resetting The Temperature Cutoff Switch **

Should the heater overheat, an automatic switch will turn the heater off and it will not come back on without being reset. The temperature cutoff switch can be reset by unplugging the unit, waiting five (5) minutes and plugging the unit back in.

⚠ CAUTION: If you need to continuously reset the heater, unplug the unit and call Dimplex North America Limited at 1-888-346-7539 for technical support.

** Not applicable on DF3215NH model fireplaces.

Remote Control

The remote control has a range of approximately 50 feet (15.25 m). It does not have to be pointed at the fireplace and can pass through most obstacles (including walls). It is supplied with 243 independent frequencies to prevent interference with other units.

Battery Installation (Figure 5)

1. Depress the tab on the battery cover on the back of the remote transmitter and remove battery cover.
2. Install two (2) AAA batteries into the remote control (included).
3. Ensure child lock is in the “unlocked” position.
4. Replace the battery cover.

! NOTE: When the  symbol is present on the remote control, it is recommended to replace the batteries promptly to maintain full functionality of the remote/fireplace.

The remote transmitter has a battery backup time of only several hours.

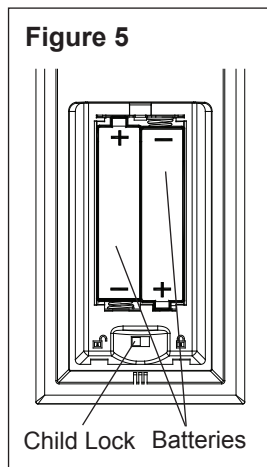

Initializing the Remote Control

1. Plug cord into 120 Volt wall outlet.
2. Ensure the Main On/Off Switch of the fireplace (Figure 4) is in the On **■** position.
3. Set the 3 Position Manual Control (Figure 4) to the **Remote** position (left position).
4. Press and hold the Initialization Button on the unit (Figure 4).
5. While holding the Initialization Button, press the Flame/Heat On/Off **⌂** button or the Purifire™ On/Off **Ⓟ** button on the remote control transmitter (Figure 6).
6. Release the Initialization Button on the unit.
7. Press the Flame/Heat On/Off button **⌂** to turn the Flame/Heat function on or press the Purifire™ On/Off button **Ⓟ** to turn the Purifire™ function on.

Figure 6

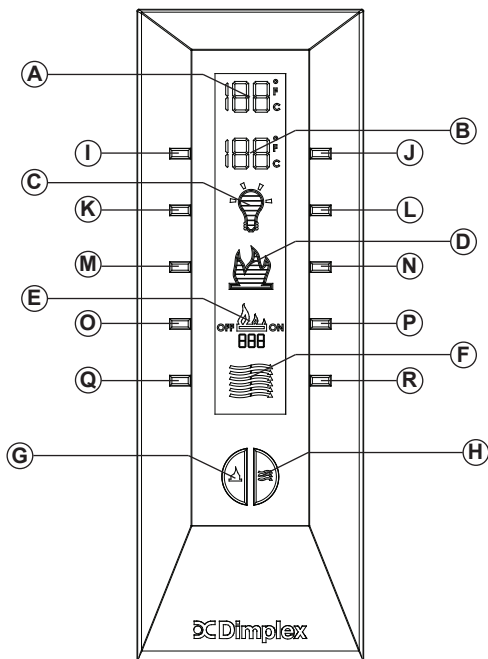

Remote Control Functions (Figure 6)

A - Room Temperature	K - Dimmer Down/Firelight Off
B - Set Temperature*	L - Dimmer Up/Firelight On
C - Dimmer/Firelight Control	M - Flame Speed Down
D - Flame Speed Control	N - Flame Speed Up
E - Slow Start/Fading Embers Control	O - Slow Start/Fading Embers Off
F - Purifire™ Speed	P - Slow Start/Fading Embers On/Timer Cycle
G - Flame & Heat On/Off	Q - Purifire™ Low Speed
H - Purifire™ On/Off	R - Purifire™ High Speed
I - Temperature Down*	
J - Temperature Up*	

* The set temperature buttons are not operational on the DF3215NH model fireplaces.

B - Set Temperature*

1. Press **G - Flame & Heat On/Off** button to turn the fireplace on.
2. Press **J - Temperature Up** to raise thermostat.
3. Press **I - Temperature Down** to lower the thermostat.
4. Press both **J - Temperature Up** and **I - Temperature Down** to change °F to °C.

* **Not applicable on DF3215NH model fireplaces.**

C - Dimmer/Firelight Control

1. Press the **G - Flame & Heat On/Off** button to turn the Flame & Heat on.
2. Repeatedly press the **L - Dimmer Up/Firelight On** or **K - Dimmer Down/Firelight Off** button to increase or decrease the brightness of the upper lights.
3. To activate the **Firelight**, continue pressing **L - Dimmer Up/Firelight On** until the **Firelight On** icon is shown on the display screen.
4. To shut the **Firelight** off continue pressing the **K - Dimmer Down/Firelight Off** button until the **Firelight Off** is shown on the display.

D - Flame Speed Control

1. Press the **G - Flame & Heat On/Off** button to turn the Flame & Heat on.
2. Press the **N - Flame Speed Up** button to increase the speed of the flame.
3. Press the **M - Flame Speed Down** button to decrease the speed of the flame.

E - Slow Start/Fading Embers Control

The **Slow Start** function simulates a starting fire. The function is automatically programmed for 30 seconds and the timer setting cannot be changed. The **Fading Embers** function simulates a fire going out. The **Fading Embers** timer can be set to 1, 5 or 10 minutes.

1. Press the **P - Slow Start/Fading Embers On/Timer Cycle** button to turn the **Slow Start/Fading Embers** function on.
2. Press the **P - Slow Start/Fading Embers On/Timer Cycle** button repeatedly to set the **Fading Embers** timer to 1, 5 or 10 minutes.
3. Press the **O - Slow Start/Fading Embers Off** button to turn the **Fading Embers** timer function off.

F - Purifire™ Speed

When the **Purifire™** function is on, the **Purifire™** symbol will flash. When off the symbol will be solid. The default setting for the **Purifire™** is set at low speed.

1. Press the **H - Purifire™ On/Off** button to turn the **Purifire™** function **On**.
2. Press the **Q - Purifire™ Low Speed** to decrease the **Purifire™** speed or the **R - Purifire™ High Speed** to increase the speed.
3. Press the **H - Purifire™ On/Off** button to turn the **Purifire™** function off.

! NOTE: To turn the Flame & Heat and Purifire™ off, press both control buttons simultaneously.

G - Flame & Heat On/Off *

Press the **G - Flame & Heat On/Off** button to turn the Flame & Heat function on. When the **B - Set Temperature** is higher then the

A - Room Temperature the heat will come on. To turn the heat off, lower the **B - Set Temperature** so that it's setting is lower than the **A - Room Temperature**. The default temperature setting is 72°F (22°C).

! NOTE: When using the remote control the heater runs on a thermostat. Press the **J - Temperature Up** or **I - Temperature Down** button to adjust the **B - Set Temperature**. Once the desired set temperature is reached the heater will turn off. The heater will cycle on and off to maintain the desired set temperature.

* Not applicable on DF3215NH model fireplaces.

Child Lock

1. Depress tab on the battery cover on the back of the remote transmitter and remove the battery cover (Figure 7).

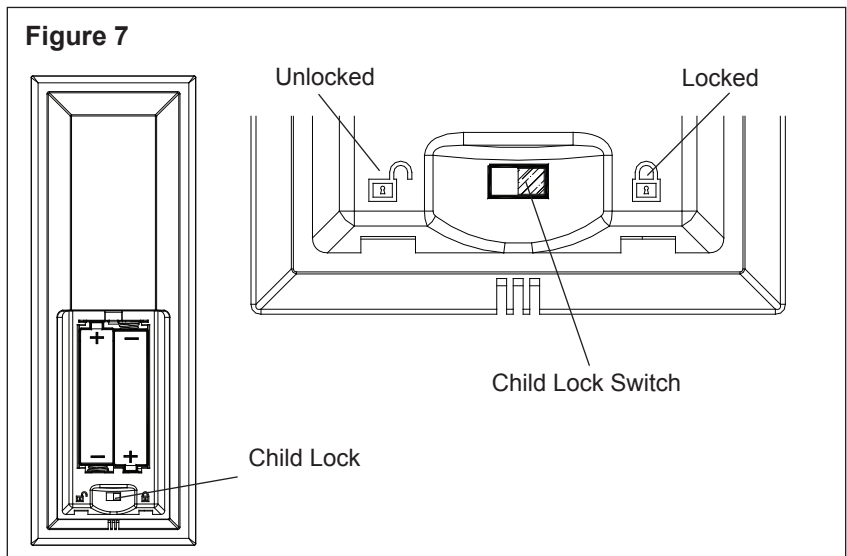

2. Move **Child Lock** tab to the right to lock the remote transmitter.
3. Move **Child Lock** tab back to the left to unlock the remote transmitter.
4. Replace the battery cover.

! NOTE: To temporarily unlock the remote transmitter press (in order) **I - Temperature Down** then **J - Temperature Up** then **K - Dimmer Down/Firelight Off**.

When the remote transmitter's backlight is illuminated the **Child Lock** is bypassed. When the backlight is off the **Child Lock** is re-activated.

Frequency Interference

If the fireplace does not respond properly to the remote control, the remote operating frequency may have to be reset. The remote control can send another frequency code to the circuit board to eliminate interference.

1. Simultaneously press the **O - Slow Start/Fading Embers Off** button and the **Q - Purifire™ Low Speed** button on the remote control.
2. “**CODE**” will appear.
3. Release the **Slow Start/Fading Embers Off** button and the **Purifire™ Low Speed** button.
4. Press and hold the Initialization Button on the unit (Figure 4).
5. Press the **G - Flame & Heat On/Off**  button on the remote and release the Initialization Button.

Your remote will now have a different frequency communicating with the fireplace.

Maintenance

 **WARNING:** Disconnect power before attempting any maintenance or cleaning to reduce the risk of fire, electric shock or damage to persons.

Light Bulb Replacement

Allow at least five (5) minutes for light bulbs to cool before touching bulbs to avoid accidental burning of skin.

Light bulbs need to be replaced when you notice a dark section of the flame or when the clarity and detail of the log ember bed exterior disappears. There are four (4) bulbs under the log set, which generate the flames and embers, and two (2) bulbs above the log that illuminate the log exterior.

Lower Light Bulb Requirements

Quantity of four (4) clear chandelier or candelabra bulbs with an E-12 (small) socket base, 60 Watt rating. Example: GE 60BC or Philips 60 CTC.

Do not exceed 60 Watts per bulb.

Helpful Hints

It is a good idea to replace all light bulbs at one time if they are close to the end of their rated life. Group replacement will reduce the number of times you need to open the unit to replace light bulbs. Care must be taken when removing the Log Set as the Log Set contains LED's and wires.

To access the lower light bulb area (Figure 8):

1. Open the Bi-fold doors.
2. Pull the front edge of the plastic Ember Bed or plastic grate up and forward until the rear tab releases from the ledge located at the bottom of the mirror.

! IMPORTANT: Only handle the Log Set by the Ember Bed.

! NOTE: Log Set fits tightly into firebox, some force may be necessary to remove.

3. Set Log Set in front of firebox.
4. Disconnect the Log Set LED wire harness from unit.
5. Lift the left side of the flame rod out of the mounting bracket.
6. Examine the bulbs to determine which bulbs require replacement.
7. Unscrew bulbs counter clockwise.

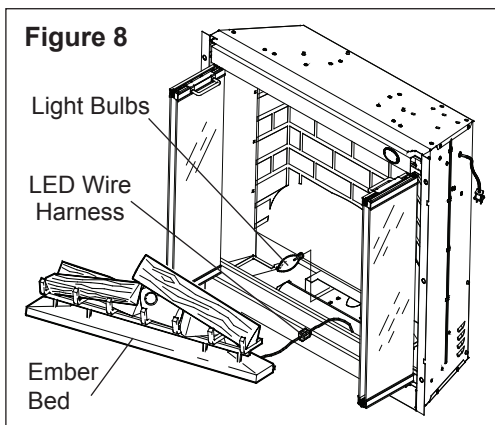

8. Insert new bulbs.
9. Install the left side of the flame rod to the mounting bracket.
10. Reconnect the Log Set LED Wire Harness.
11. Replace the Log Set by inserting the rear tab of the Ember Bed under the mirror and push down on the front edge of the Ember Bed until it snaps into place (Figure 9).

! NOTE: Ensure the Log Set is installed tightly under the back ledge to prevent light leakage.

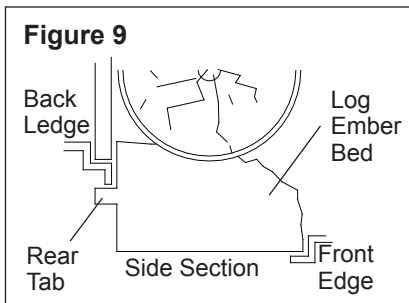

12. Close the Bi-fold doors.

Upper Light Bulb Requirements

Quantity of two (2) clear chandelier or candelabra bulbs with an E-12 (small) socket base, 25 Watt rating.

Do not exceed 25 Watts per bulb.

To access the upper light bulb area:

1. Open the Bi-fold doors.
2. Remove upper light bracket with a screwdriver (Figure 10).
3. Replace bulb.
4. Reassemble in the reverse order as above.

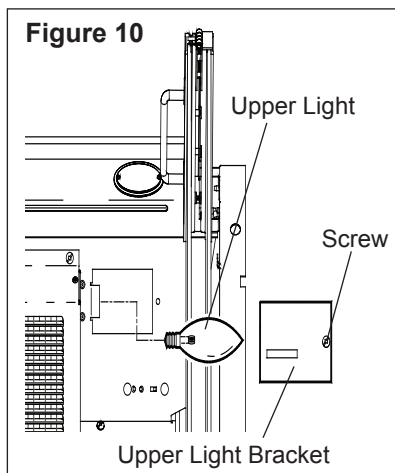

Purifire™ Filter (Figure 11)

The Purifire™ filter supplied in your fireplace is reusable and washable. The filter should be cleaned or replaced on average once a year. To clean the filter gently tap filter on a hard surface to dislodge any loose dirt or debris, and then clean with water. No soap or cleaning products are recommended. The filter size is 20 inches x 10 inches

x 1 inch rated at MERV 10. If using an after market filter follow the manufacturers recommended replacement instructions.

To replace filter:

1. Open the Bi-fold doors.
2. Remove the three (3) mounting screws from the Air Filter Bracket.
3. Remove the Air Filter Bracket assembly from the firebox.
4. Slide Filter out of Air Filter Bracket.
5. Replace filter and reassemble in reverse order as above.

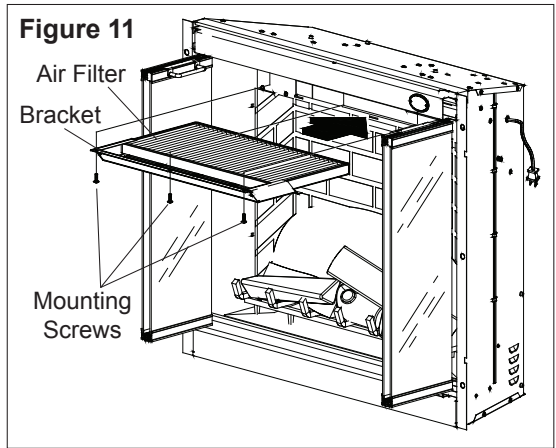

! NOTE: If after market air filter is used ensure it is installed according to the manufacturer's recommended instructions.

Glass Cleaning

The glass is cleaned in the factory during the assembly operation. During shipment, installation, handling, etc., the glass may collect dust particles, these can be removed by dusting lightly with a clean dry cloth.

To remove fingerprints or other marks, the glass can be cleaned with a damp cloth. To prevent scratching, do not use abrasive cleaners or spray liquids on the glass surface.

Fireplace Surface Cleaning

Use a cloth dampened with warm water only to clean painted surfaces of the electric fireplace. Do not use abrasive cleaners.

Ten Year Limited Warranty

Products to which this limited warranty applies

This limited warranty applies to the following model of your newly purchased Dimplex electric fireplace **DF3215**, **DF3215NH** and to newly purchased Dimplex fireplace surrounds (mantels) and trims. This limited warranty applies only to purchases made in any province of Canada except for Yukon Territory, Nunavut, or Northwest Territories or in any of the 50 States of the USA (and the District of Columbia) except for Hawaii and Alaska. This limited warranty applies to the original purchaser of the product only and is not transferable.

Products excluded from this limited warranty

Light bulbs and Purifire™ filters are not covered by this limited warranty and are the sole responsibility of the owner/purchaser. Products purchased in Yukon Territory, Nunavut, Northwest Territories, Hawaii, or Alaska are not covered by this limited warranty. Products purchased in these States, provinces, or territories are sold AS IS without warranty or condition of any kind (including, without limitation, any implied warranties or conditions of merchantability or fitness for a particular purpose) and the entire risk of as to the quality and performance of the products is with the purchaser, and in the event of a defect the purchaser assumes the entire cost of all necessary servicing or repair.

What this limited warranty covers and for how long

Products, other than fireplace surrounds (mantels) and trims, covered by this limited warranty have been tested and inspected prior to shipment. Subject to the provisions of this warranty, Dimplex warrants such products to be free from defects in material and workmanship for a period of 10 years from the date of the first purchase of such products as follows: (a) a repair or replacement warranty on defective products or parts, including in-home services, for the first year following the date of first purchase; and (b) thereafter, a replacement of parts warranty on defective products and parts (with no in-home services) for the 9 year period commencing on the first anniversary of first purchase and ending on the tenth anniversary of the date of first purchase.

Dimplex fireplace surrounds (mantels) and trims covered by this limited warranty have been tested and inspected prior to shipment and, subject to the provisions of this warranty, Dimplex warrants such products to be free from defects in material and workmanship for a period of 1 year from the date of first purchase of such products. Warranty services do not include in-home services.

The above section is a summary only of your warranty rights. Please review the remaining provisions of this warranty for your specific rights.

The limited 10 year warranty period for products other than fireplace surrounds (mantels) and trims and the limited 1 year warranty period for fireplace surrounds (mantels) and trims also applies to any implied warranties that may exist under applicable law. Some jurisdictions do not allow limitations on how long an implied warranty lasts, so the above limitation may not apply to the purchaser.

What this limited warranty does not cover

This limited warranty does not apply to products that have been repaired (except by

Dimplex or its authorized service representatives) or otherwise altered. This limited warranty does further not apply to defects resulting from misuse, abuse, accident, neglect, incorrect installation, improper maintenance or handling, or operation with an incorrect power source.

What you must do to get service under this limited warranty

Defects must be brought to the attention of Dimplex Technical Service by contacting Dimplex at 1-888-DIMPLEX (1-888-346-7539), or 1367 Industrial Road, Cambridge Ontario, Canada N1R 7G8. Please have proof of purchase, catalogue/model and serial numbers available when calling. Limited warranty service requires a proof of purchase of the product.

What Dimplex will do in the event of a defect

In the event a product or part covered by this limited warranty is proven to be defective in material or workmanship during (i) the 10 year limited warranty period for products other than fireplace surrounds (mantels) and trims, and (ii) the 1 year limited warranty period for surrounds (mantels) and trims, you have the following rights:

- Limited warranty service will be performed solely by dealers or service agents of Dimplex authorized to provide limited warranty services.
- **For products (other than surrounds (mantels) and trims) for the period ending at midnight on the first anniversary of the date of first purchase**, Dimplex will in its sole discretion either repair or replace such defective product or part without charge. If Dimplex is unable to repair or replace such product or part, or if repair or replacement is not commercially practicable or cannot be timely made, Dimplex may, in lieu of repair or replacement, choose to refund the purchase price for such product or part. *This limited warranty entitles the purchaser to on-site or in-home warranty services.* Accordingly, Dimplex will be responsible for all labour and transportation costs associated with the repair or replacement of the product or part except as follows: (i) charges may be levied for travel costs incurred to travel to the purchaser's site where the product is located if the purchaser's site is beyond 30 miles (48 km) from the closest service depot of Dimplex's dealer or service agent; and (ii) the purchaser is solely responsible for providing clear access to all serviceable parts of the product.
- **For products (other than surrounds (mantels) and trims) for the period commencing at 12:01 a.m. on the day after the first anniversary of the first purchase and ending at midnight on the tenth anniversary of the date of first purchase**, this limited warranty entitles the purchaser to replacement parts only without charge. If Dimplex is unable to replace such part, or if replacement is not commercially practicable or cannot be timely made, Dimplex may, in lieu of replacement, choose to refund the purchase price for such part. The purchaser shall not be entitled to on-site or in-home warranty services. The purchaser shall be responsible for all expenses incurred for the removal of the part and installation of the replacement part including, without limitation, all shipping costs and transportation costs to and from the authorized dealer's or service agent's place of business and all labour costs. Such costs shall not be the responsibility of Dimplex.
- **For surrounds (mantels) and trims for the period ending at midnight on the first anniversary of the date of first purchase**, Dimplex will in its sole discretion

either repair or replace such defective surrounds (mantels) and trims or part thereof without charge. If Dimplex is unable to repair or replace such product or part, or if repair or replacement is not commercially practicable or cannot be timely made, Dimplex may, in lieu of repair or replacement, choose to refund the purchase price for such product or part. The purchaser shall not be entitled to on-site or in-house services. The purchaser is responsible for all expenses incurred for repair or replacement of such product or part including, without limitation, all shipping costs and transportation costs to and from the authorized dealer's or service agent's business and all labour costs. Such costs shall not be the responsibility of Dimplex.

- On-site or in-home services not provided under this warranty may be performed at the purchaser's specific request and expense at Dimplex's then-current rates for such services.

What Dimplex and its dealers and service agents are also not responsible for:

IN NO EVENT WILL DIMPLEX, OR ITS DIRECTORS, OFFICERS, OR AGENTS, BE LIABLE TO THE PURCHASER OR ANY THIRD PARTY, WHETHER IN CONTRACT, IN TORT, OR ON ANY OTHER BASIS, FOR ANY INDIRECT, SPECIAL, PUNITIVE, EXEMPLARY, CONSEQUENTIAL, OR INCIDENTAL LOSS, COST, OR DAMAGE ARISING OUT OF OR IN CONNECTION WITH THE SALE, MAINTENANCE, USE, OR INABILITY TO USE THE PRODUCT, EVEN IF DIMPLEX OR ITS DIRECTORS, OFFICERS, OR AGENTS HAVE BEEN ADVISED OF THE POSSIBILITY OF SUCH LOSSES, COSTS OR DAMAGES, OR IF SUCH LOSSES, COSTS, OR DAMAGES ARE FORESEEABLE. IN NO EVENT WILL DIMPLEX, OR ITS OFFICERS, DIRECTORS, OR AGENTS BE LIABLE FOR ANY DIRECT LOSSES, COSTS, OR DAMAGES THAT EXCEED THE PURCHASE PRICE OF THE PRODUCT.

SOME JURISDICTIONS DO NOT ALLOW THE EXCLUSION OR LIMITATION OF INCIDENTAL OR CONSEQUENTIAL DAMAGES, SO THE ABOVE LIMITATION OR EXCLUSION MAY NOT APPLY TO THE PURCHASER.

How State and Provincial law apply

This limited warranty gives you specific legal rights, and you may also have other rights which vary from jurisdiction to jurisdiction. The provisions of the United Nations Convention on Contracts for the Sale of Goods shall not apply to this limited warranty or the sale of products covered by this limited warranty.



Dimplex North America Limited
1367 Industrial Road • Cambridge ON
Canada N1R 7G8

Dimplex[®]

1-888-346-7539 • www.dimplex.com

© 2010 Dimplex North America Limited